



Applications: Wimag Repeaters, CCTV, Detection, Base stations

Designed and manufactured to minimise health and safety risks associated with working at height and to support the installation and maintenance of equipment secured on any highway structure.

Attributable to its unique and patented hinge design, the system incorporates a 2 metre extension pole, to which a variety of applications can be mounted to and then installed, above any pole or highway structure.

The extension pole is secured to a hinged arm, operated via an extended crank handle, which allows the thread to be reached. The low torque mechanism enables the process of raising mounted applications up to 2 metres above existing structures or lowering them to within 1500mm from ground level.

The hinge mechanism is mounted through standard fixing points using a U-bolt and can also be retrofitted easily utilising this method. Dependent upon the requirements of the installer and the type of application being mounted, the EasyWynd® system can accommodate both round and square poles and both extension tubes are available.

Advantages

- ◆ Quick and simple installation
- ◆ Eradicates the requirement for access equipment, after installation
- ◆ Removes all 'working at height' health and safety implications
- ◆ All maintenance can be conducted from ground level
- ◆ Cost effective due to unnecessary 'working at height' access equipment
- ◆ In the absence of road closure: minimal disruption is caused to motorists and pedestrians



Technical Specification

Extension poles must allow equipment to be mounted 2m above fixing point on existing pole.

Extension poles must have a mechanism to allow lowering from ground level by a single operative.

Extension poles must be coated with e-coat and powder coated.

Extension poles must be rated to have 8.8kgs of equipment installed.

Extension pole mounting pole must be aluminium square section.

Extension poles must have the ability to be lowered 150 degrees of vertical position.

Extension poles must allow the maintenance of any mounted equipment to be carried out from ground level.

Extension poles must require a crank handle for the mechanism to perform.

All extension poles must be provided to the above specification by NAL Ltd, or an equally approved manufacturer.

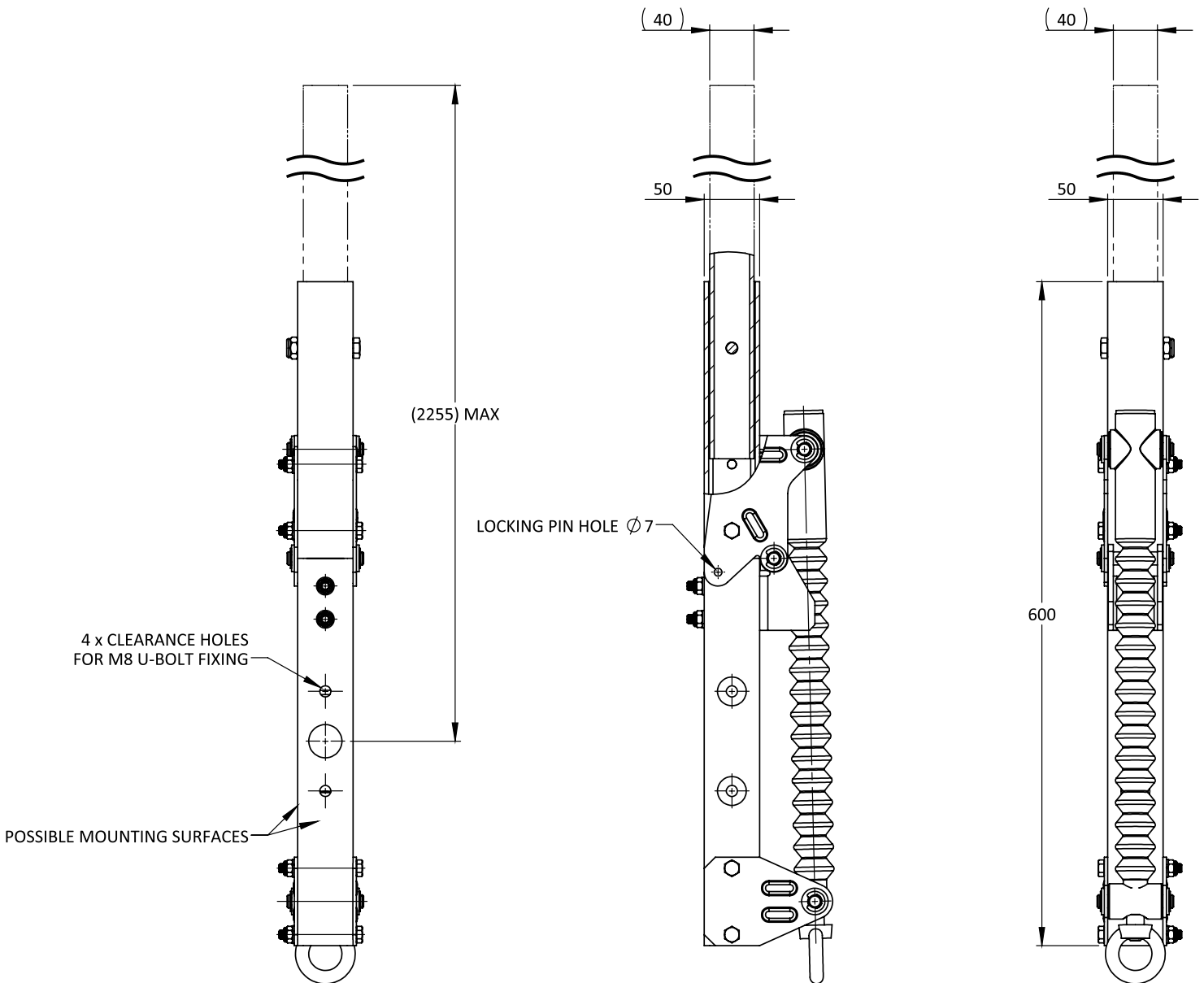

A CRH COMPANY

Weir Lane, Worcester, WR2 4AY

Tel:01905 427100

Fax:01905 427030

Email:sales@nal.ltd.uk