



Access Chambers

MCX RapidSTACK™ A – B Chambers



NAL RapidSTACK™ A chambers are fully compliant to the current specification for highway works, 1500 series, and are an acceptable solution to highways jointing chambers.

All are manufactured to the latest MCX 0815 specification.

Each RapidSTACK™ chamber ring has a unique 76mm bedding area for the final specified cover to sit on, ensuring the full B125 or D400 loading is accurately distributed.

The high strength of these chambers means that no internal bracing is required during the initial installation.

Advantages

- ◇ Unique design of interchangeable sections
- ◇ Wide range of sizes available from 450mm to 3500mm
- ◇ Depth in multiples of 150mm, stackable system
- ◇ Chambers are tested and certified to perform to the vertical load requirements specified in pr-EN 124 and BS EN124: 1994
- ◇ No internal bracing required during initial installation
- ◇ RapidSTACK™ Highway chambers are tested and certified to withstand D400 (40t) loadings by independent UKAS accredited test houses
- ◇ RapidSTACK™ Highway chambers meet the latest HA104/09 requirements for a full 76mm width bedding area, required for associated cover and frame to sit*

* Although RapidSTACK™ conform to this standard, it should be noted that this standard only relates to access/gully tops (covers)



A CRH COMPANY

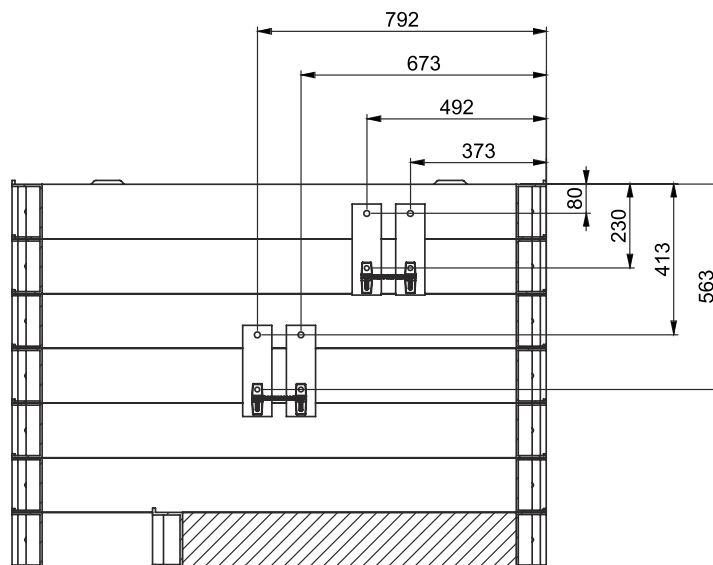
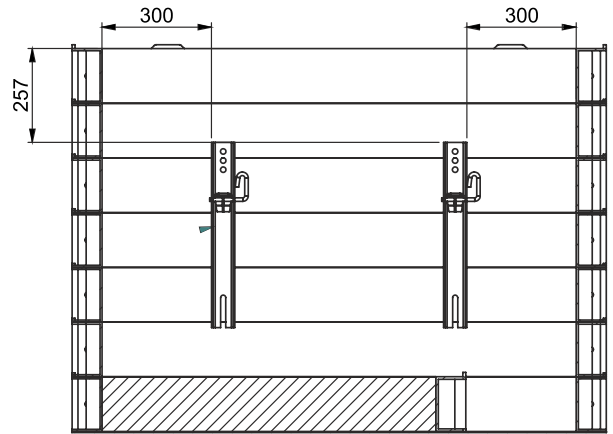
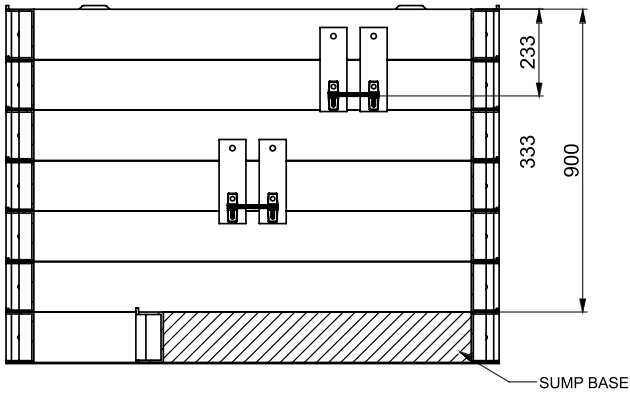
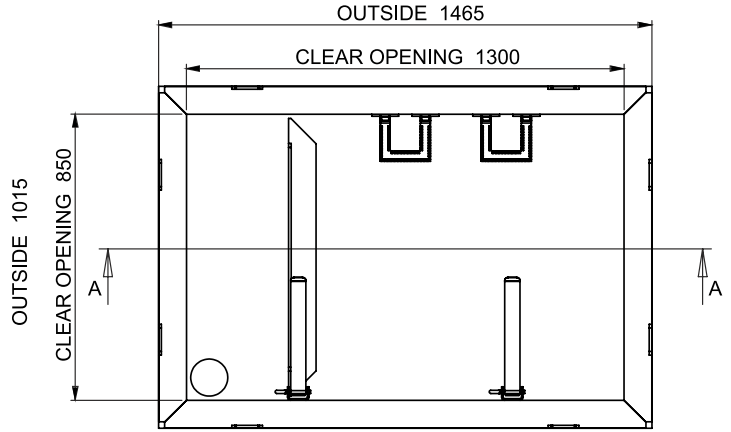
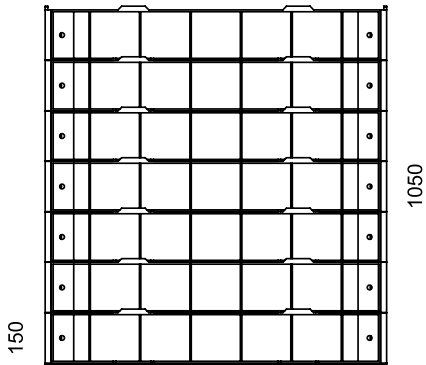

A CRH COMPANY

T: +44 (0)1905 427100
 F: +44 (0)1905 427030
 E: sales@nal.ltd.uk
 W: www.nal.ltd.uk

NAL
 Weir Lane
 Worcester
 WR2 4AY