



# Temporary Products

## Temporary Cable Shroud



### Applications:

#### Traffic Signals, Street Lighting, Signage

The NAL Cable Shroud is an innovative system that has been developed for use with the NAL Temporary Foundation System, specifically when they are being used to secure any illuminated or solar powered street furniture. The Cable Shroud creates a void around the Temporary Foundation enabling the storage and protection of excess electric cable and/or associated equipment such as batteries.

The Shroud completely removes the requirement for expensive and disruptive traffic management, reducing the footprint surrounding the foundation by up to 50%, therefore greatly increasing public accessibility during site works in busy urban areas. The Cable Shroud is manufactured in two parts and connected by a hinge mechanism to enable it to be easily retrofitted on site. The system can be securely locked together with padlocks or security bolts eliminating risk of equipment theft. Polyester Powder coated in white with a central Class RA2 reflective red band to adhere to DFT standards this ensures the units are highly visible yet non-intrusive to motorists, cyclists and pedestrians.

### Advantages

- ◆ Protects the public from dangerous equipment
- ◆ Protects and secures equipment from vandalism and theft
- ◆ Increases accessibility on the footway by up to 50%
- ◆ Eliminates the requirement for traffic management
- ◆ Reduces the risk of personal injury claims
- ◆ Enables work programmes to continue during major public events
- ◆ Removes the area traditionally used to discard litter
- ◆ Unaffected by adverse weather conditions



A CRH COMPANY

Front

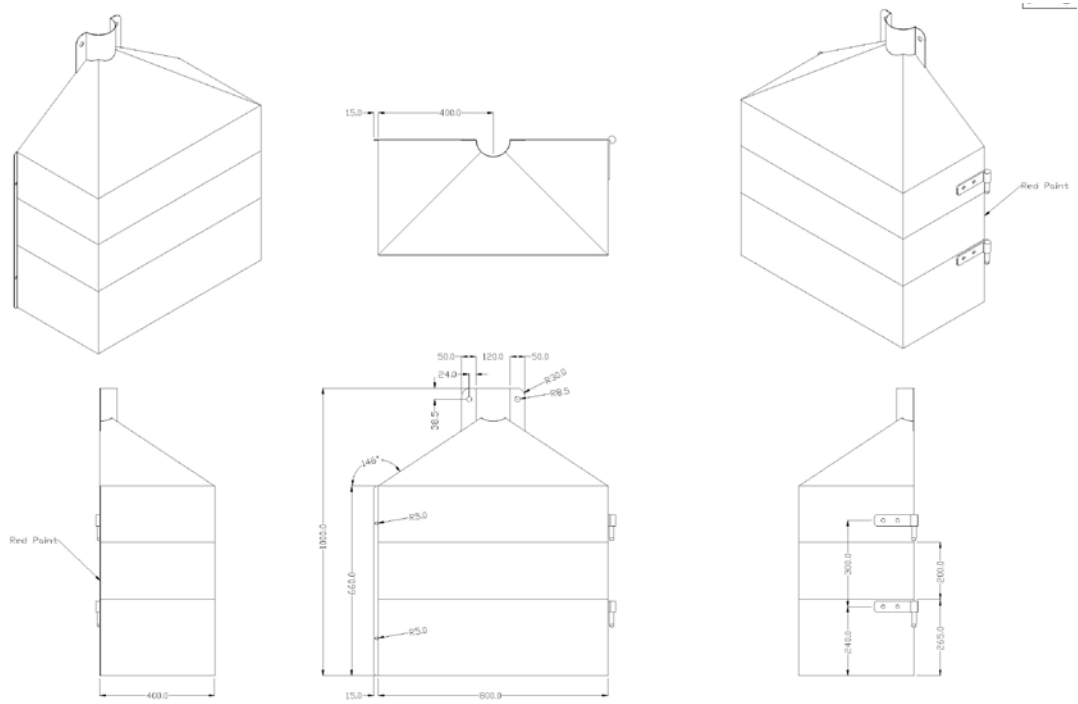

Back

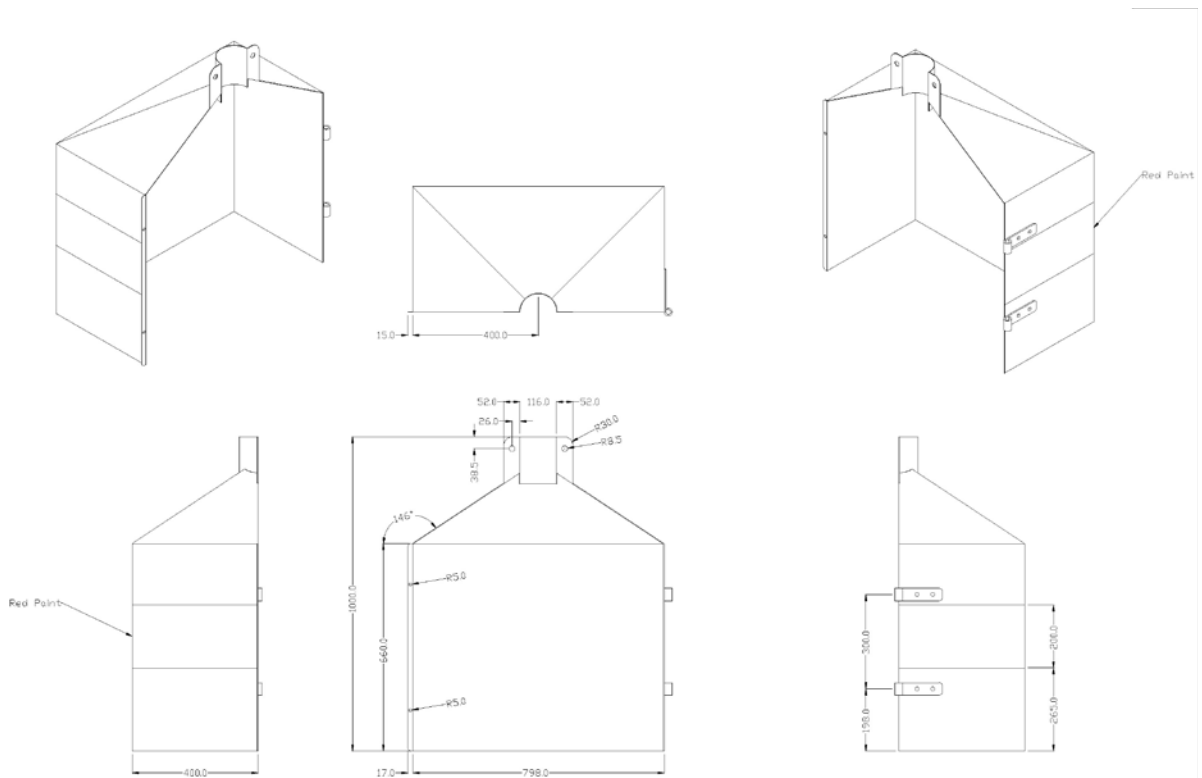

A CRH COMPANY

T: +44 (0)1905 427100  
 F: +44 (0)1905 427030  
 E: sales@nal.ltd.uk  
 W: www.nal.ltd.uk

NAL Ltd  
 Weir Lane  
 Worcester  
 WR2 4AY

