

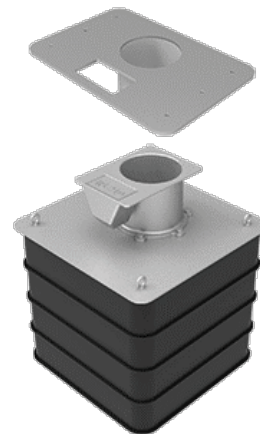

# Retention Sockets

## High Power Charger Foundation



### Applications:

#### Petroleum Forecourt / Service Station Charging Bays

##### Overview

The NAL High Power Charger Foundation is a universal system designed to accommodate all manufactured and bespoke high-power EV charging dispenser units whilst improving the installation and simplifying the cabling process.

Facilitating the use of cables up to 240mm<sup>2</sup>, systems are fully future proofed to allow for any replacements, upgrades and additions required in the event of damage, advancements in technology and increased demand.

##### Implementation

The solution utilises the NAL Retention Socket and is available with a range of adapter plates to fit bespoke designs and to accommodate manufacturer-specific high-power charging dispenser units.

Installed at civils stage, and prior to the delivery of charger units if required, Retention Sockets are sealed with a pedestrian plug ensuring footways remain free of trip hazards and open to the public. The relevant adapter plate is then installed within the Retention Socket and the charge unit is secured to the adapter plate to provide an easy and improved access to utility cables.



A CRH COMPANY

---

## Advantages

- ◇ **Feature**  
Simplifies civils installation
- ◇ **Benefit**  
Shallow depth requirements reduce the amount of wet concrete – eradicating associated inconvenience and cost
- ◇ **Feature**  
Universal system
- ◇ **Benefit**  
No lost time incurred waiting for manufacturers specific foundation fixings
- ◇ **Feature**  
Fully future proofed
- ◇ **Benefit**  
No requirement for costly excavation work in the event of upgrade or damage and foundations can be installed ahead of time to meet future increased demand
- ◇ **Feature**  
Completion of civils work prior to delivery of High Power Charger dispensers
- ◇ **Benefit**  
No lost time incurred due to conflicting schedules
- ◇ **Feature**  
Allows ducting to enter from any location
- ◇ **Benefit**  
Flexibility allows for multiple cable sizes
- ◇ **Feature**  
Positively connected ducting
- ◇ **Benefit**  
Provides simple and improved access to cabling, reducing installation and maintenance times
- ◇ **Feature**  
Pedestrian plug seal
- ◇ **Benefit**  
No disruption to the public or any health and safety implications

---

## NAL High Power Charger Foundation Product Specification

Retention Socket head must be constructed from cast steel to GS240 or ductile iron to BS2789 500-7.

Retention Sockets must be capable of withstanding high speed vehicle impact forces to steel posts with a wall thickness of 6mm. Retention Sockets must be able to withstand impact without any structural surround to the top 80mm of the unit. A valid impact test must result in a post deflection greater than 30 degrees. All sockets must be impact tested. Test data and independent certification must be available to substantiate claims for sockets and foundations.

Posts must be positively secured into the retention sockets and be able to withstand a turning moment of 3.4kNm through a load of 230kg @ 1.5metre from the centre of post without any rotation.

Securing mechanism of sockets to post must not damage the coating or galvanised surface of the post.

All fixings which secure posts in place must be housed below ground ensuring no risk of damage, vandalism or theft.

Retention Socket pedestrian plugs must be tested to EN124 - B125 (12.5 Tonne) loading.

Pedestrian plugs must be able to be stored within the socket to enable rapid deployment in the case of an emergency.

All operating components must be serviceable on site without removing the socket.



---

# NAL High Power Charger Foundation Product Specification

The Retention Socket must be capable of accommodating graded surfaces in paved areas such as those at pedestrian crossings.

Suppliers of Retention Sockets must be able to supply EN40 & BD94/17 foundation design calculations for all sizes and depths of Retention Sockets supplied.

In the event of an impact on a Retention Socket that has been installed according to the manufacturer's instructions, the Retention Socket must be warranted against failure. In such circumstances the manufacturer must be responsible for replacement of the Retention Socket and all associated re-installment costs.

Retention Sockets will have the ability to accept adapter plates for all EV rapid chargers.

Retention Sockets will be positively fixed to the chamber below.

Access chambers must be manufactured from high grade thermoset material and be completely recyclable at the end of life.

Access chambers shall be a twin-wall design and assembled from stackable 150mm deep sections.

Access chambers must be tested to withstand a minimum vertical load of 90 tonnes without the use of concrete surround for support. Only the Retention Socket will require concrete.

External walls shall have an external rib of width no greater than 15mm, positioned at the bottom of each section, to allow full section depth compaction.

External walls shall be free from moulding voids that will negatively impact the effectiveness of compaction which should be in accordance with the new roads and street works act (1991).

Access chambers must not be jointed in the corner or require mechanical fixing to achieve strength.

Access chamber sections must have the ability to be adjusted in height during installation by being cut laterally without loss of strength to allow for transitional gradient installations.

All Retention Sockets with access chamber must be provided to the above specification by NAL Ltd or any equally approved manufacturer.



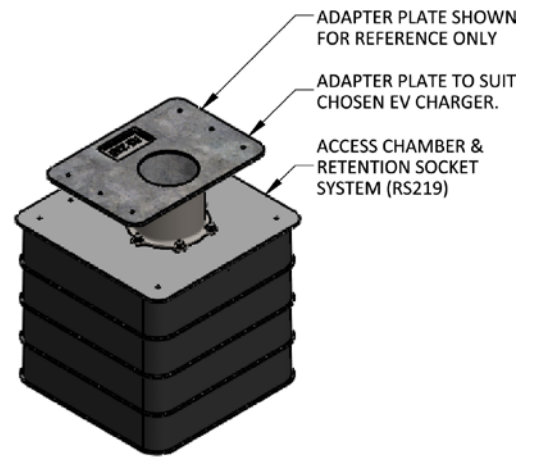
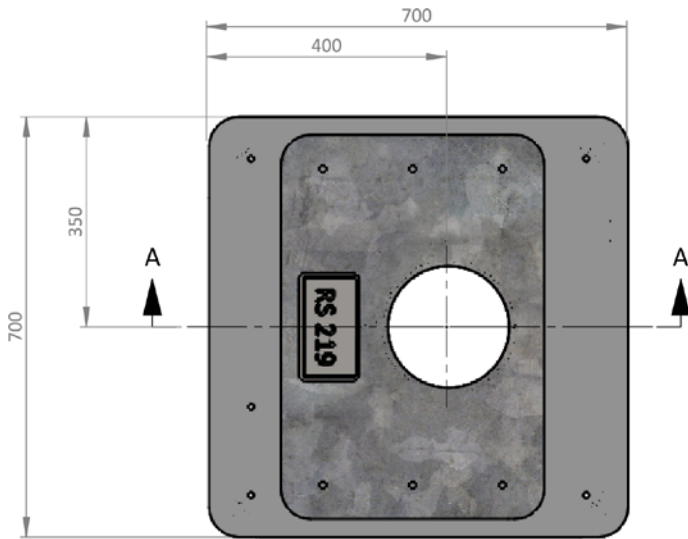

ISOMETRIC VIEW  
SCALE 1 : 20

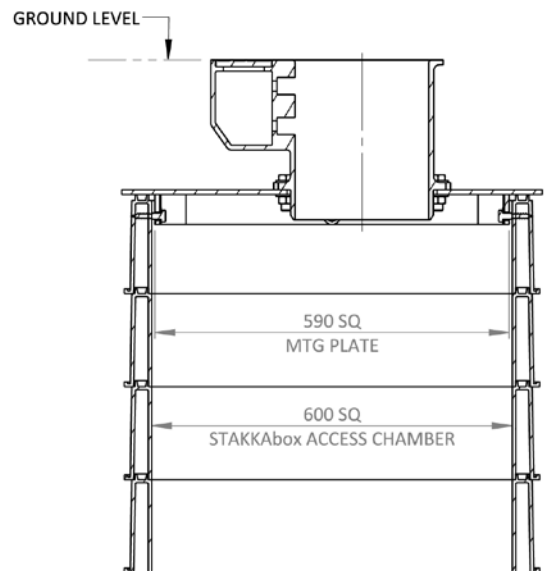
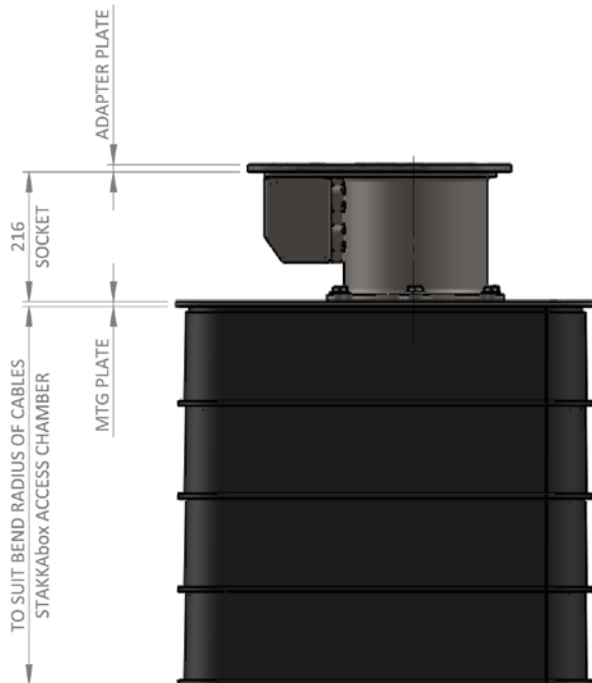

SECTION A-A  
(ADAPTER PLATE REMOVED FOR CLARITY)



A CRH COMPANY

T: +44 (0)1905 427100  
E: sales@nal.ltd.uk  
W: www.nal-ev.com

NAL  
Weir Lane  
Worcester  
WR2 4AY