

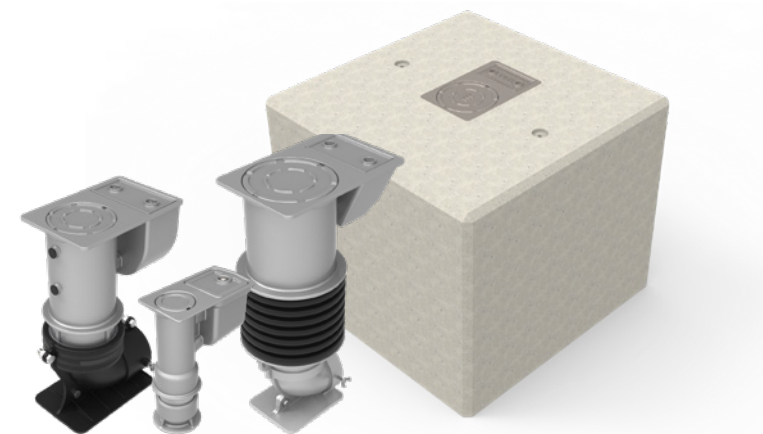

# Retention Sockets

## Motorway Communications



### Applications:

**Emergency Phone Bases, ROTTM Signs, Signposts, CCTV, Rader Posts, Street Lighting**

The Retention Socket with or without adapter plate enables all types of motorway furniture to be secured as well as fully being fully demountable.

Available in all sizes and types, it is suitable for illuminated and non illuminated furniture. Adapter plates are made to suit the specific fixing points and positions of the surface mounted furniture.

The Retention Socket allows the civils installation work to take place without the furniture being on site. This system offers many advantages over the traditional foundation system such as simplifying the cabling of illuminated furniture as well as future proofing all installations.

Pre-cast sockets enable installation of the foundations without wet trade on site, in any weather condition, at any time.

### Advantages

- ◇ Simplifies civils installation
- ◇ Allows civils work to be completed prior to street furniture arrival
- ◇ No trip hazards left at end of civils work
- ◇ Deeper foundations smaller footprints for larger street furniture
- ◇ 100mm bottom entry duct access option for cables
- ◇ Electrical installation can be done at ground level
- ◇ Allows simple quick and simple removal of furniture
- ◇ Pre-cast option eliminates wet trade on site
- ◇ Pre-cast installed in any weather at any time
- ◇ Foundation design to EN40 or BD9407
- ◇ Cat 0 design certified



A CRH COMPANY

---

## Purchase Specification

The socket head shall be constructed of cast steel to ISO 3755 230-450 or Ductile Iron to BS2789 500-7, galvanised on all internal and external surfaces.

The socket shall be capable of withstanding impact forces from vehicle impact to steel posts with wall thickness up to 6mm.

All assembly screws shall be M12 A2 stainless steel. It shall contain two M16 A2 stainless steel lateral fixing setscrews inside a locking chamber.

This locking chamber shall be covered with a locking lid, EN124-B125 load rated fitted with RS worm lock.

The socket shall have a galvanised steel base.

The socket shall contain a protective pressure plate.

ST4 Concrete and A393 mesh must be used for all installations of Shallow Foundation Retention Sockets.

All operating components shall be serviceable on site.

Retention Sockets must have the ability to be reduced in depth on site easily to a min of 450mm.

Suppliers of Retention Sockets must be able to supply EN40 and BD94/07 foundation design calculations for all sizes and depths of retention sockets supplied.

Securing mechanism of sockets to post must not damage the coating or galvanised surface of the post.

All fixings which secure posts in place must be housed below ground ensuring no risk of damage, vandalism or theft.

Posts must be positively secured into the Retention Sockets and be able to withstand a turning moment of 3.4kNm through a load of 230kg @ 1.5metre from the centre of post without any rotation.

All Retention Sockets must be provided to the above specification by NAL Ltd or any equally approved manufacturer.

### Non-illuminated

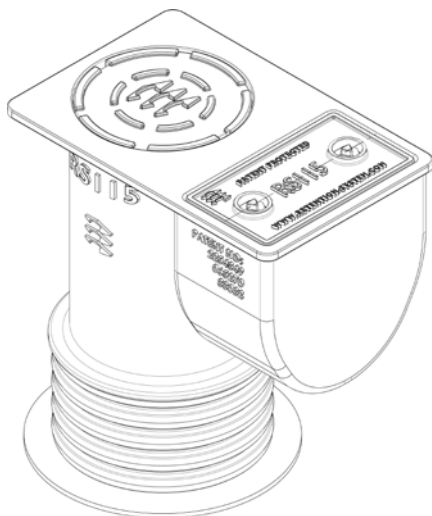

### Shallow Foundation

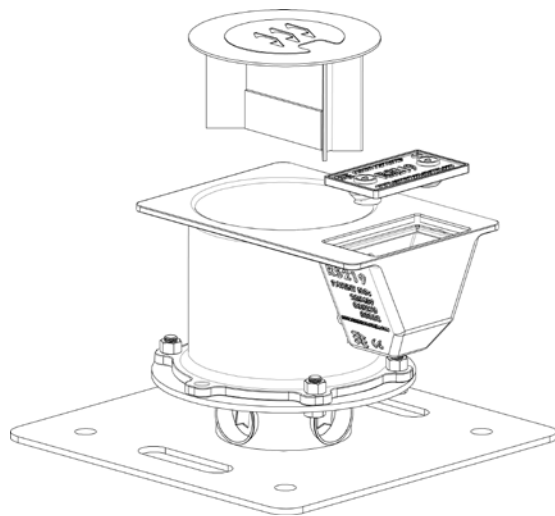

A CRH COMPANY

Pre-cast Foundation

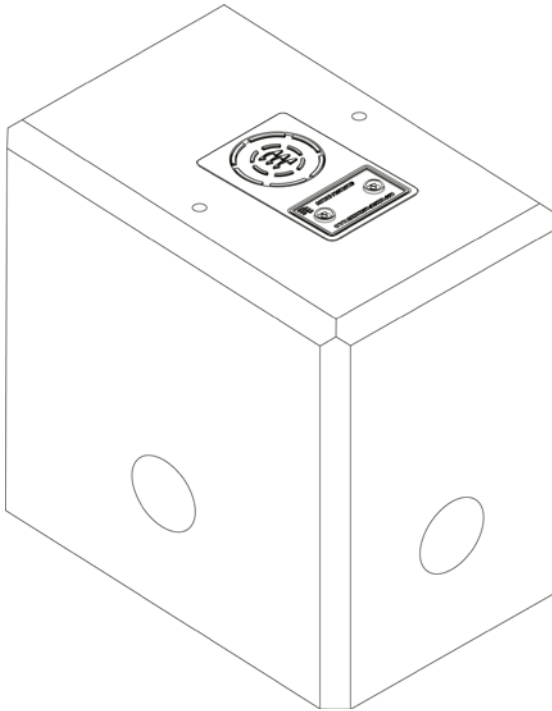

Duckfoot Bend

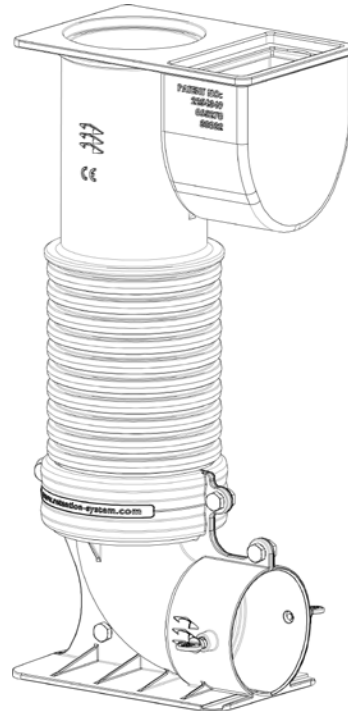

Adapter Plate for Surface Mounted Furniture

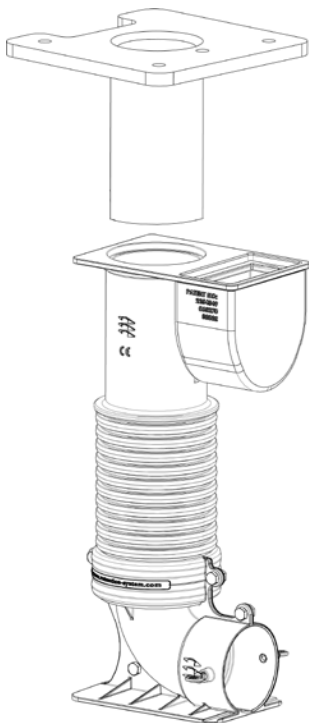

Tee Bend

